

My Money Can Help

Bible Verse:

2 Corinthians 9:7

Extra Bible Verse:

2 Corinthians 8:12

Provide:

- Junk mail
- Scarves or bandannas
- Masking tape
- Tables
- Brown paper bags

To Do:

- A week prior to the meeting, ask coaches to save their junk mail.
- Place two tables at one end of the room.
- Tape a starting line about 25 feet away from the tables.
- Place a stack of junk mail on each table.
- Put brown paper bags on the tables.

Purpose:

This meeting can help children understand that making, spending, and giving money is a part of Christian stewardship. Money can go where you individually cannot go. And when you combine your gifts with the gifts of others, you can do greater things than you could do alone.

Bible Material:

Money that Ministered (Philippians 4:10-20)

Warm-up

Get-involved Activity
(10 minutes)

As the children arrive, make two teams. Ask each team member to select a partner. Explain that partners must work together. Partners will have scarves tied around their legs so that they will walk three-legged.

Approximately 25 feet from the starting line, place two stacks of junk mail and two brown paper bags. The first set of partners will walk to the stack, pick up one item, put it in the brown paper bag, pick up the bag, and walk back to the starting line where they put the bag down. The next set of partners must pick up the bag, carry it to the stack of junk mail, put the bag down, put one more item in the bag, and then carry the bag back to the starting line.

As play continues, the bags get heavier and heavier. Each partner can use only one hand. If the bag is dropped, they must retrieve each item in the bag and continue. If the bag splits, they must return to where the items are stacked, get another bag, and return to the starting line.

Continue this activity for about 10 minutes or until all have arrived for the meeting.

Workout

Group Study
(30 minutes)

1. Begin WORKOUT. Blow a whistle to signal the beginning of WORKOUT.

Ask the children to move to the taped circle on the floor. Announce that this meeting is about a man who was a church planter; that is, he went from place to place meeting people, telling them about Jesus, and establishing churches. He wrote many letters, some of which are collected as books in the Bible. Explain that the Bible story is about Paul and the Philippians who gave money to him so that he could travel to various places and tell people about Jesus.

2. Tell the Bible story. Introduce the person portraying Paul. Ask the children to listen carefully as he tells the story so that they can answer the questions you have written on poster board.

Money that Ministered

I am Paul, a tentmaker. You would call me a missionary. I do have a mission. God gave me this mission. I must tell as many people as I can about Jesus and what He has meant to me. He turned my life around on the road to Damascus. I haven't been the same since. I am filled with joy and love.

Life is not always easy. Since Jesus' death and resurrection, I have been traveling throughout the Mediterranean, Tyrrhenian, and Aegean Seas to start churches. These churches are groups of people who gather in homes or shops or around the local well to tell of their love for God, Jesus, and each other. I am thankful for all the people I have met and what they have done for me.

The folks I met in Philippi are so special. They were some of the first people with whom I shared the story of Jesus. They helped me so much. I had no food, clothing, or place to stay. They opened their homes to me and made me feel welcomed. Praise God! They were so good to me early in my travels. No other church helped me like the people at Philippi. I am committed to telling the message of Jesus to as many people as possible. The Philippians made that possible.

Recently Epaphroditus brought me the gift they sent me. Now I have everything I need. God sees that I have everything I need, just as he supplied His greatest gift, Jesus Christ.

—based on *Philippians 4:10-20*

Thank the storyteller. Review the questions with the children. Summarize by saying: "This story shows that great things can be done for God when you put what you have together. Then you can do so much more."

Provide:

- A whistle
- Masking tape

To Do:

- Tape a circle on the floor large enough for all of the children.

Provide:

- Poster board
- Simple Bible costume
- Masking tape
- Marker

To Do:

- Arrange for one of the coaches to present the monologue while wearing the costume.
- Make a photocopy of the monologue.
- Write the following questions for the monologue on poster board.
 - *Who helped Paul early in his travels as a missionary?*
 - *How was Paul helped by the people that he met during his travel?*
 - *Where was Paul's life changed?*
 - *Did more than one person help Paul?*

To Do:

- Make photocopies of the Bible verse in sign language.

God loves/loveth a cheerful giver (2 Corinthians 9:7).

3. Learn sign language. Paul wrote letters to communicate with friends that he had met during his travels. There are many ways of communicating. People with hearing impairments communicate by signing. Ask the children to “listen” while you sign the Bible verse. Then, without saying anything, sign the verse to them. Practice ahead of time and use the following as a guide.

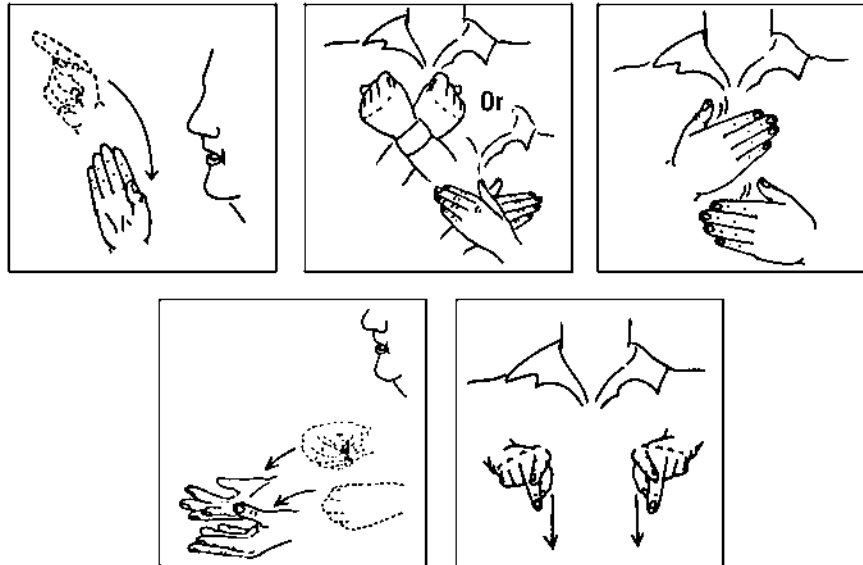

Ask the children if they can guess what the verse might be. If no one guesses the verse, say the verse to them. Ask them to sign with you. Then ask them to repeat the verse aloud with you as you sign the verse together. Sign the verse three times.

Summarize by saying, “Some Christians have been given the gift of signing to communicate with the deaf. They use their gifts by signing in churches, at places of work, and where people live. They are cheerful givers.”

Provide:

- 11-by-17-inch colored paper
- Scissors

To Do:

- Make photocopies of the billfold instructions on the next page and the gift check on the last page of this meeting.
- Cut 11-by-17-inch paper into 11-by-11-inch squares.

4. Make origami billfolds. Communicating the story of Jesus was important to Paul and should be important to you. When you cannot go to places away from where you live, you send missionaries to tell other people about Jesus. This requires money. No gift is too small.

Say: “You will be making origami billfolds and inserting checks on which you write a gift that you feel you can give to tell others about Jesus.” Ask the children to think of gifts that they have which they can share. These gifts are not necessarily money. Lead them to write these gifts on their checks.

Distribute 11-by-11-inch squares of colored paper to each child. Following the instructions, demonstrate how to fold the billfold. TEAM coaches should practice this before the meeting and be ready to help those who have difficulty folding the billfold. *See the diagram on the next page.*

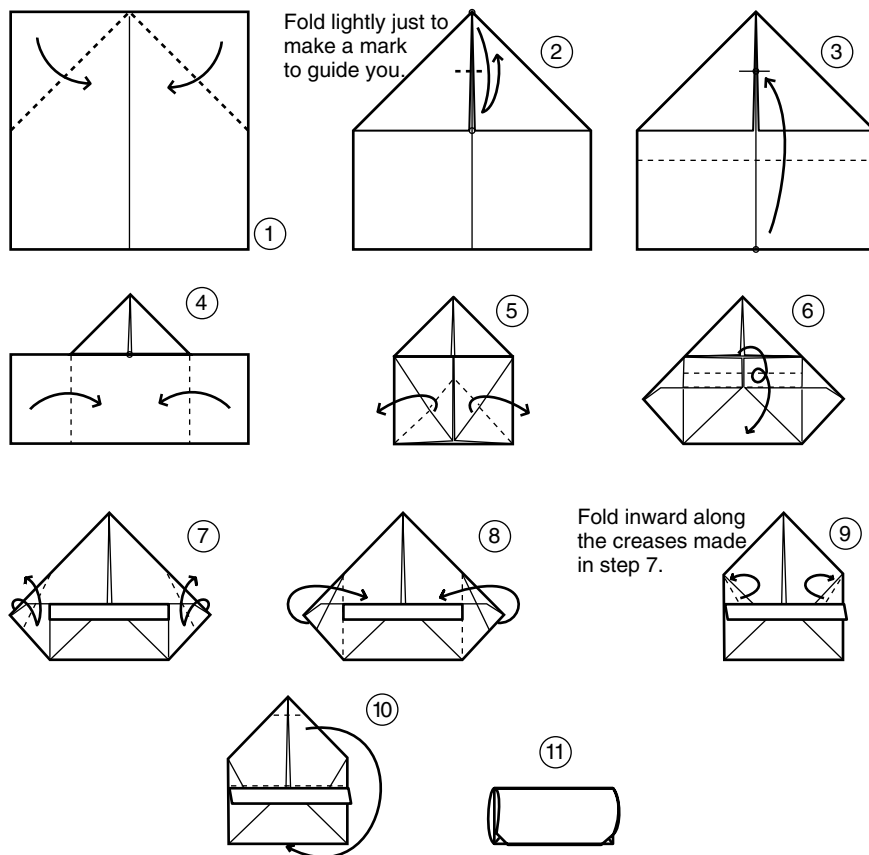

When the children have completed their billfolds, give them the checks which you have copied for them. Say: “Do you know someone who serves as a missionary? Do they have a family? Missionaries must leave their homes and sometimes travel many, many miles to tell others about Jesus. Often they will not have the things we have in the United States.” (If your church has church members on the mission field, you can tell a story about that missionary.)

Say: “On the check we have given to you, write something you would like to share with a missionary. If you do not know a missionary, perhaps there is someone in your neighborhood who does not come to church. Write what you would like to share with that person or family. Then place your check in the billfold you have made.”

5. Pray. After the children have completed their checks, ask them to form a circle and hold hands. Say: “Take some time to thank God for the gifts you have been given. I will start the prayer and squeeze the child’s hand on my right when I am finished. If the child on my right would like to say a thank-you prayer, he will say his prayer and then squeeze the child’s hand on his right. If you do not wish to pray, please squeeze the child’s hand on your right and let the prayer time continue.”

Stretching

Activity Page Time
(20 minutes)

Answers for activity pages are found on the last page of this meeting. You may choose to provide photocopies of this page to the STRETCHING coaches.

The Tournament

Games and Activities
(20 minutes)

Provide:

- A whistle

Blow the whistle to begin THE TOURNAMENT. Choose from the following games and activities.

Provide:

- A dollar bill

Pass the Buck

Choose three players to be watchers and send them out of the room. Give a dollar bill to a player in the group and tell him not to let the watchers know he has the bill. He can fold or wad the bill up if he wants. Bring the watchers back into the room. Instruct everyone in the group except the watchers to mingle around the room, shaking hands with each other and saying, "How do you do?" As they shake hands, they must pass the dollar bill from one player to another without letting the watchers see what they are doing. The dollar bill must stay in a players' hands at all times. While this is going on, tell the watchers to carefully observe the group and try to find out who has the dollar bill. After two or three minutes the coach calls time and all the players in the room hold their fists in front of them. The watchers then try to figure out who has the dollar bill. Play several rounds.

Remind the children that God desires for us to "pass our bucks" around to help other people.

Provide:

- Four quarters
- Four stickers of four different colors.

Secret Money

Give a quarter to four players in the group. At the coach's signal players mingle around the room, shaking hands and asking, "Can I help you?" When a player with a quarter shakes the hand of a tenth person, he gives that person the quarter and shouts, "Ten!" When the original quarter holder gets the quarter back, he sits down. When all original quarter holders get their quarters back, the game ends.

Remind players that God asks you to help others by sharing your money. When you share with others, God will bless you by taking care of your needs.

To do:

- Place a different colored sticker on each of the four quarters.

Find Your Dollar

Cut up play dollar bills into four to six pieces. Make sure you have one piece for each player in your group. For example, if you have 20 children in your group, you will need five dollar bills cut into four pieces each. Mix the pieces up and place them in a paper bag. Instruct the players to stand in a circle. Hold the bag and tell the players to take one piece of the play dollar bills. At the coach's signal players search for others who have the connecting pieces to their dollar bill. The first group to put their dollar together wins.

Remind players that when you combine your gifts with the gifts of others, you can do greater things than you could do alone.

Cool Down

Refreshments and Conclusion
(10 minutes)

Say: "Today you have been hearing about Paul, who used many different ways to communicate the love of Jesus with other people. He walked, took boats, wrote letters, and spoke to large groups of people in the region where he lived. You will be making a 'walking' salad for refreshments. That means, you will walk around the tables collecting items to complete your salad. As you do so, remember Paul and how he had to depend on families and people he met in his journeys to supply his food and a place to stay."

Allow the children to fill the center of the apple with raisins. Add marshmallows, or chocolate chips if desired.

When the children have completed their snacks, reassemble the group. Give each child a "gift check" that you have prepared. Say: "You have learned about money and gifts and how they may be a help or hindrance. Each of you has been given special gifts by God. You must choose how to use these gifts. Your parents, friends, teachers, and other family members cannot make you use the gifts you have been given."

Express your appreciation to the children for what they have meant to you. Tell them that the envelopes contain checks from you which express your thanks for them. Ask them to remember that "God loves a cheerful giver." Dismiss the children.

Provide:

- Play dollars
- Paper bag

To do:

- Cut the play dollars into pieces and place them in the paper bag.

Provide:

- Apples
- Raisins
- Marshmallows
- Bowls
- Knives
- Spoons
- Chocolate chips
- Envelopes
- Photocopies of the "gift check" from the last page of the meeting.
- Napkins

To Do:

- Core apples, making a hole in the middle of the apple. (Do not slice it.)
- Place food in bowls with spoons on tables.
- Write "gift checks" for each child and put one in each envelope. Write each child's name on a separate envelope.

Meeting 4: Answers for Activity Pages

Grade 1–3

Find the Picture

Happy face

Grades 4–6

My Money Can Help

Maria pleased God.

10 cents, 10 cents, 30 cents

The Tithe

1. tenth

2. the Lord

3. yes

4. 20 cents, 50 cents

My Money Matters

hymnals, supplies, literature, Bibles, missions, heat, music, seminaries, salaries, helping



Date _____

Pay to the order of _____

For _____



Date _____

Pay to the order of _____

For _____



Date _____

Pay to the order of _____

For _____